

**ITS**

**TEST REPORT**

**ELECTROPLATING TEST REPORT**

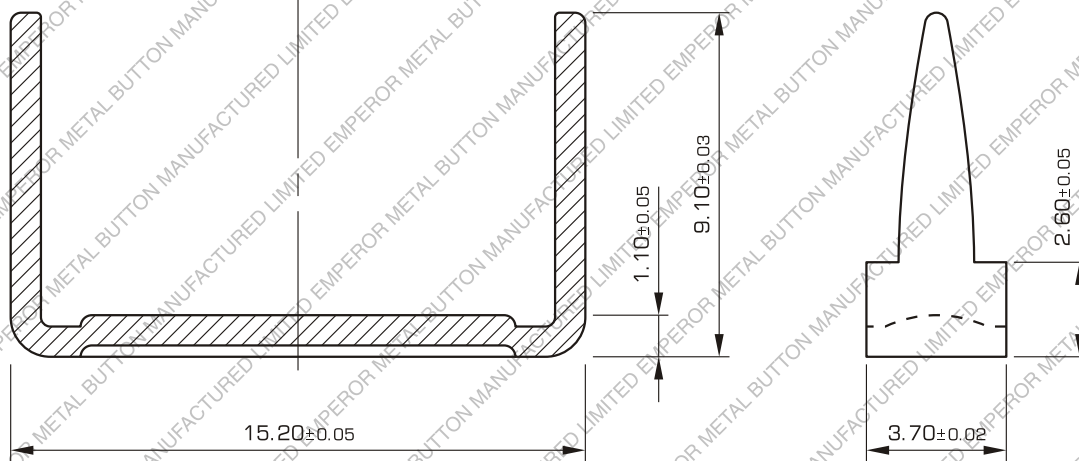

TITLE  
**TH125B C PART**



MATERIAL  
**0.80  
BRASS**

HARDNESS

SCALE  
**5 : 1**

SHEET NO.  
**1 OF 1**

**EMPEROR**  
METAL BUTTON MFY. LTD.

UNLESS OTHERWISE SPECIFIED

DIM	MM±	DIM	MM±	ANGLE±
.00	.2	.00	.02	