

ITS

TEST REPORT

ELECTROPLATING TEST REPORT

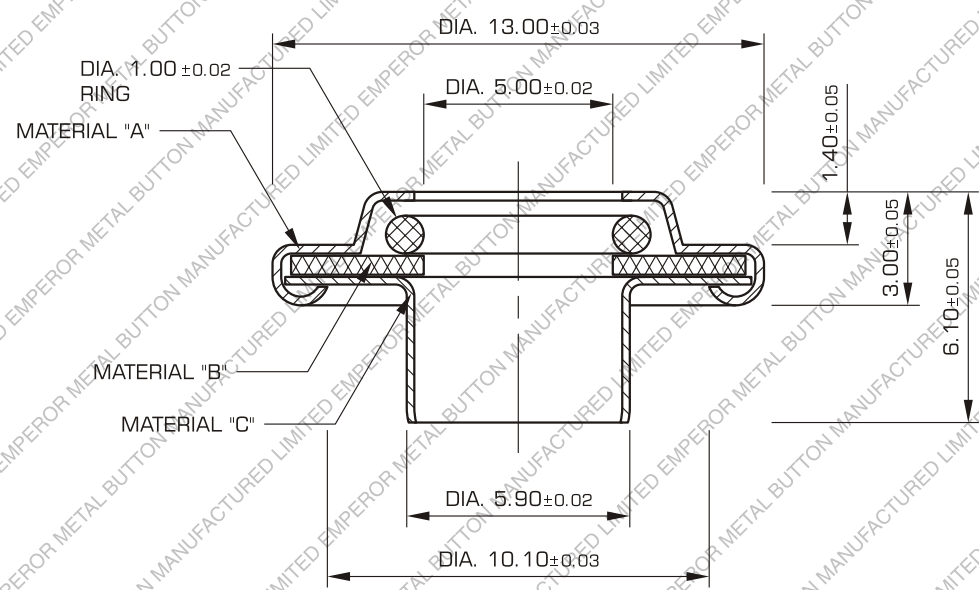
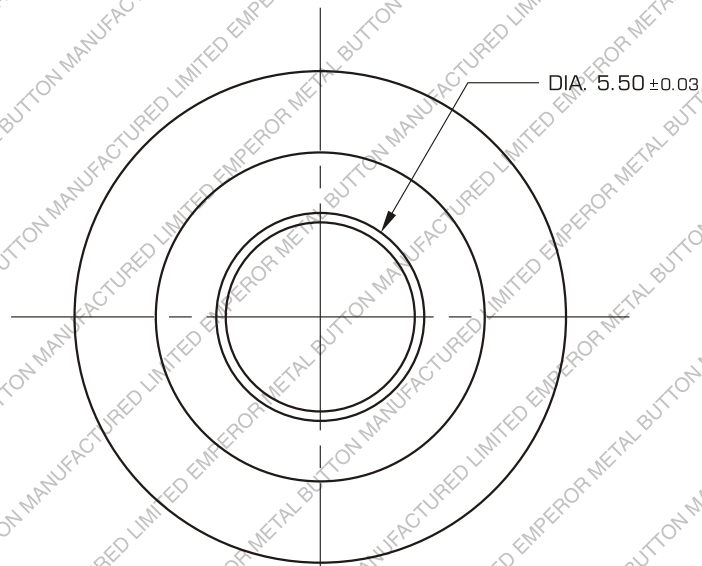

TITLE

306 B PART



MATERIAL
 A-0.23 BRASS
 B-0.50 BRASS
 C-0.20 BRASS

HARDNESS

SCALE

5 : 1

SHEET NO.

1 OF 1

EMPEROR

METAL BUTTON MFY. LTD.

UNLESS OTHERWISE SPECIFIED

DIM	MM±	DIM	MM±	ANGLE±
.00	.2	.00	.02	