

ITS

TEST REPORT

ELECTROPLATING TEST REPORT

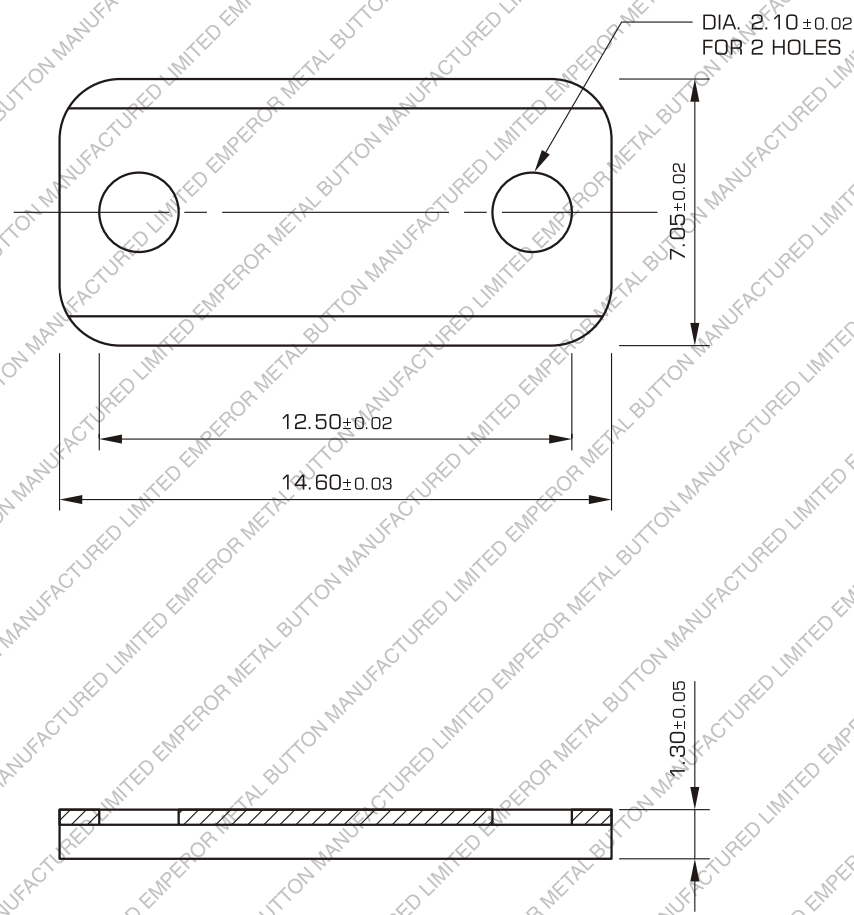

TITLE
TH1130 D PART



MATERIAL
**0.40
BRASS**

HARDNESS

SCALE
5 : 1

SHEET NO.
1 OF 1

EMPEROR
METAL BUTTON MFY. LTD.

UNLESS OTHERWISE SPECIFIED

DIM	MM±	DIM	MM±	ANGLE±
.00	.2	.00	.02	