

ITS

TEST REPORT

ELECTROPLATING TEST REPORT

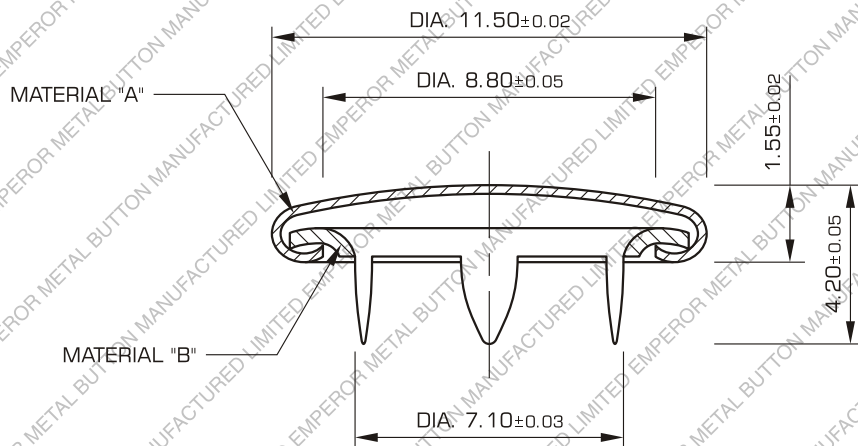
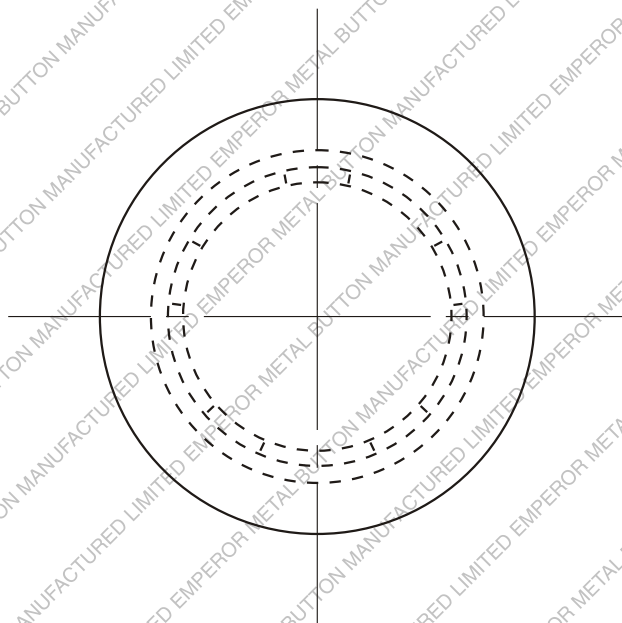

TITLE

333-18#A PART



MATERIAL  
A-0.23 BRASS  
B-0.40 BRASS

HARDNESS

SCALE  
5 : 1

SHEET NO.  
1 OF 1

EMPEROR

METAL BUTTON MFY. LTD.

UNLESS OTHERWISE SPECIFIED

DIM	MM±	DIM	MM±	ANGLE±
.00	.2	.00	.02	